



TFT MODULE SPECIFICATION

RVA15MD-NUC64B V2

HB, IPS 1.54” display datasheet
Rev. 1.0
2026-05-26

Riverdi Sp. z o.o.

Nowy Swiat 36
80-299 Gdansk, Poland
VAT ID: PL5842767153
Registration number (KRS): 0000923967

+48 587 703 116

Office hours: 9:00 to 17:30 CET (Mon-Fri)

contact@riverdi.com

riverdi.com

ITEM	CONTENTS	UNIT
LCD Type	TFT/Transmissive/Normally Black/IPS	/
Size	1.54	inch
Viewing Direction	Free	/
Outside Dimensions (W x H x D)	66.30 x 52.10 x 16.56	mm
Active Area (W x H)	27.72 x 27.72	mm
Pixel Pitch (W x H)	0.1155 x 0.1155	mm
Resolution	240 x 240 (RGB)	/
Brightness	750	cd/m ²
LCD Interface Type	SPI	/
Color Depth	262K	/
Pixel Arrangement	RGB Vertical Stripe	/
LCD Driver	ST7789	/
With/Without Touch	With Projected Capacitive Touch Panel	/
CTP Driver	ILI2130	/
Touch Interface Type	I2C	/
Bonding Technology	Optical Bonding	/
Weight	29	g

Note 1. RoHS3 compliant

Note 2. LCM weight tolerance: ± 5%.

1. REVISION RECORD

REV NO.	REV DATE	CONTENTS	REMARKS
1.0	2026-05-26	Initial Release	

2. CONTENTS

1.	REVISION RECORD	3
2.	CONTENTS	4
3.	MODULE CLASSIFICATION INFORMATION	5
4.	MODULE DRAWING	6
5.	ABSOLUTE MAXIMUM RATINGS	7
6.	ELECTRICAL CHARACTERISTICS	7
7.	BACKLIGHT ELECTRICAL CHARACTERISTICS	8
8.	ELECTRO-OPTICAL CHARACTERISTICS	9
9.	INTERFACES DESCRIPTION	12
9.1	CN7	12
9.2	CN10	13
10.	EXTERNAL MEMORY	14
11.	CAPACITIVE TOUCH SCREEN PANEL SPECIFICATIONS	14
11.1	Mechanical characteristics	14
11.2	Electrical characteristics	14
12.	INSPECTION	15
13.	LEGAL INFORMATION	15
14.	CONTACT	16

3. MODULE CLASSIFICATION INFORMATION

RV	A	15	M	D	NUC	64	B	V2
1.	2.	3.	4.	5.	6.	7.	8.	9.

NO.	PARAMETER	SYMBOL
1.	BRAND	RV - Riverdi
2.	PRODUCT TYPE	A - Accessories
3.	DISPLAY SIZE	15 - 1.54"
4.	MODEL SERIAL NO.	M - Standard Brightness, IPS
5.	RESOLUTION	D - 240 x 240 px
6.	INTERFACE	NUC - goldpins for Nucleo board
7.	NUMBER OF PINS	64
8.	VERSION	B - 8MB NOR Flash memory
9.	MODULE REVISION	V2

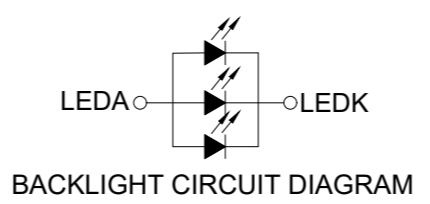
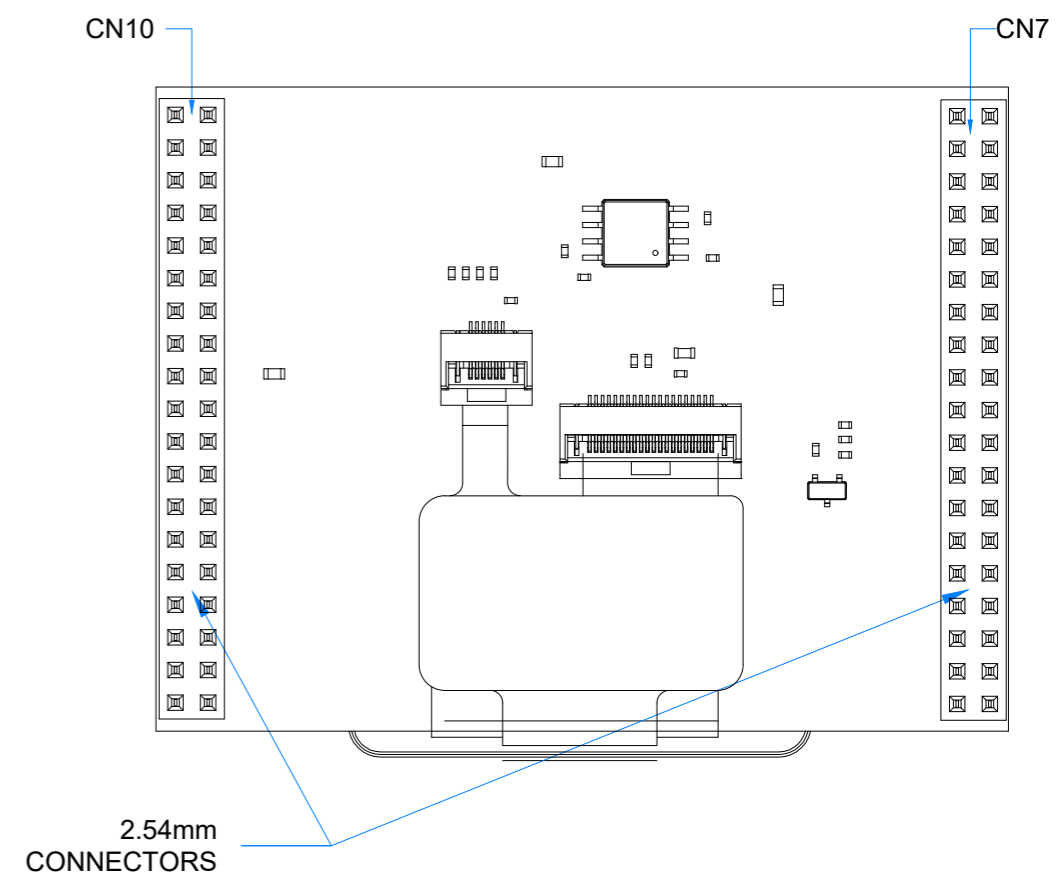
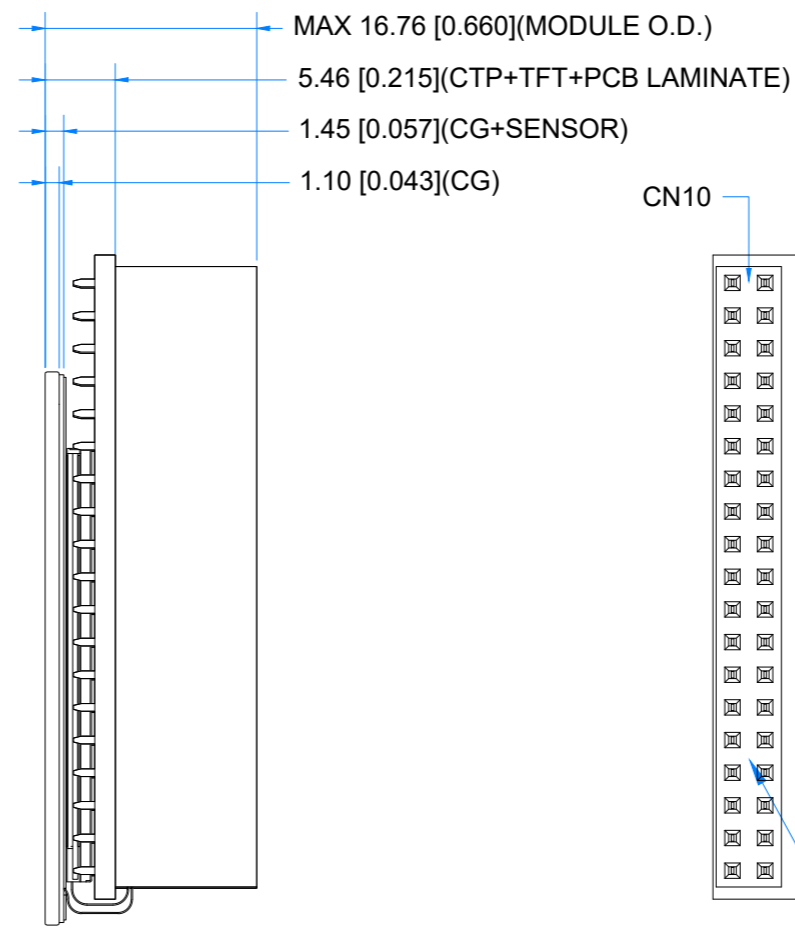
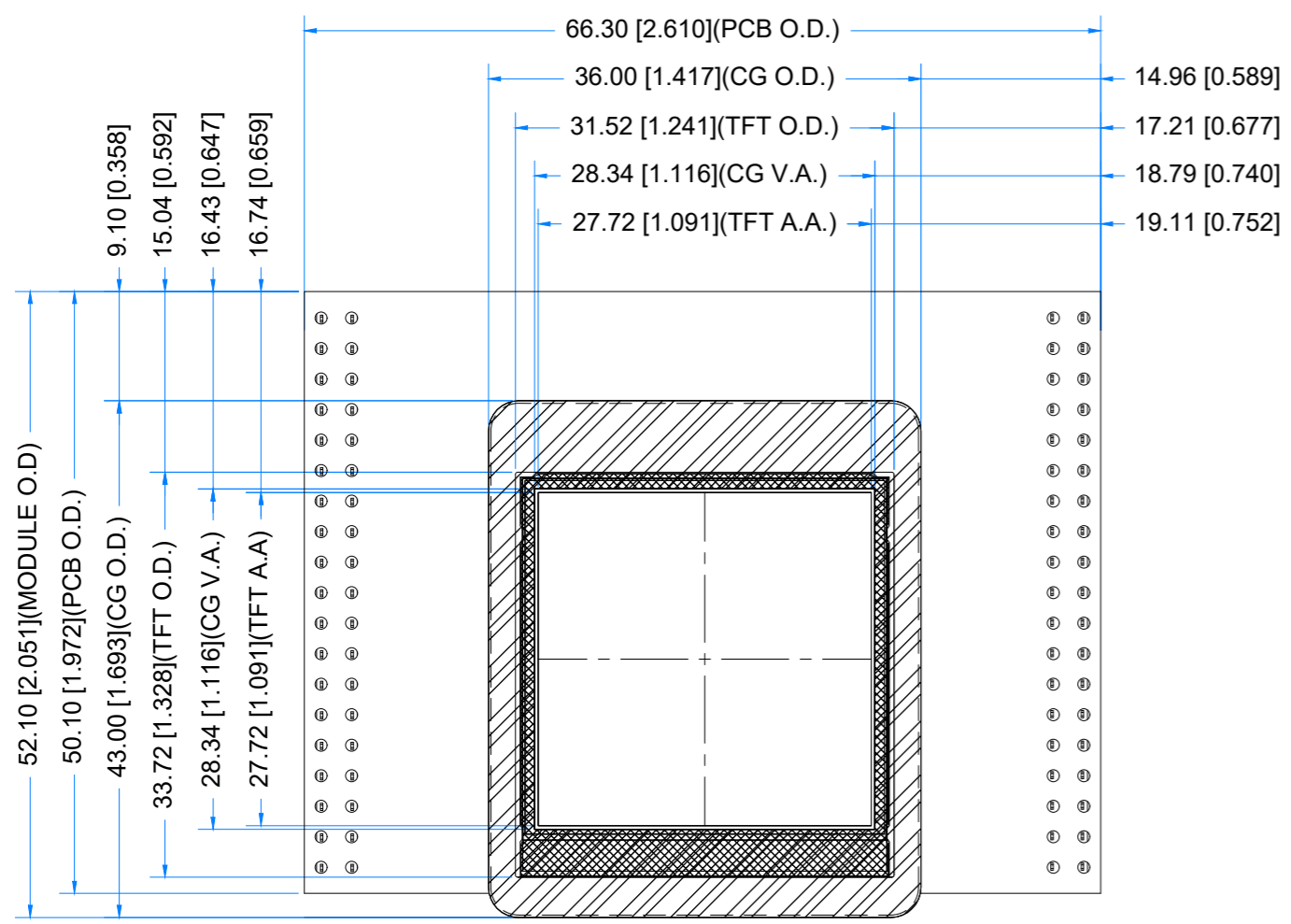

TFT NOTES:

1. DISPLAY TYPE: TFT, TRANSMISSIVE, NORMALLY BLACK
2. RESOLUTION: 240*240
3. VIEWING ANGLE: FREE
4. DRIVER IC: ST7789P3
5. OPERATING VOLTAGE: $V_{DD}=2.8V$
6. SURFACE LUMINANCE: $750cd/m^2$
7. BACKLIGHT: 3 WHITE LEDS, $V_f=2.9V$, $I_f=60mA$

TP NOTES:

1. TP STRUCTURE: GFF
2. CG THICKNESS: 1.10mm
3. DRIVER IC: ILI2130
4. SURFACE HARDNESS: $\geq 6H$
5. TRANSMITTANCE: $>85\%$

GENERAL NOTES:

1. OPERATING TEMPERATURE: $-20^{\circ}C \sim 70^{\circ}C$
2. STORAGE TEMPERATURE: $-30^{\circ}C \sim 80^{\circ}C$
3. WITHOUT INDIVIDUAL TOLERANCE: $\pm 0.2mm$
4. RoHS COMPLIANT

PN: RVA15MD-NUC64B V2

SN:

DRAWN: M.Stabinski 2026.05.26 1:0.59

CHECKED: K. Szymanski 2026.05.26 [mm]

APPR: A. Demko-Karolczuk 2026.05.26 ISO A3

P. 1 of 1

5. ABSOLUTE MAXIMUM RATINGS

PARAMETER	SYMBOL	MIN	MAX	UNIT
Supply Voltage (Logic)	IOVCC	-0.3	4.6	V
System Voltage	VCC _{2.8}	-0.3	4.6	V
Input Voltage	V _{IN}	-0.3	V _{DD} +0.3	V
Operating temperature	T _{OP}	-20	70	°C
Storage temperature	T _{ST}	-30	80	°C

Note. The above are maximum values. If exceeded, they may cause permanent damage to the unit.

6. ELECTRICAL CHARACTERISTICS

PARAMETER	SYMBOL	MIN	TYP	MAX	UNIT
Interface operation voltage	IOVCC	1.7	1.8	3.3	V
System voltage	V _{CC}	2.5	2.8	3.3	V
System power supply current	I _{VCC}	-	44	-	mA
Input High Voltage for LCD	V _{IH}	0.7IOVCC	-	IOVCC	V
Input Low Voltage for LCD	V _{IL}	VSS	-	0.3IOVCC	V
Output High Voltage for LCD	V _{OH}	0.8IOVCC	-	IOVCC	V
Output Low Voltage for LCD	V _{OL}	VSS	-	0.2IOVCC	V

7. BACKLIGHT ELECTRICAL CHARACTERISTICS

PARAMETER	SYMBOL	MIN	TYP	MAX	UNIT	NOTE
Backlight Driving Voltage	V_{LED}	4	5	6	V	Notes 1, 2
Backlight Driving Current	I_{LED}	-	60	-	mA	
Backlight Lifetime	-	-	30,000	-	hours	Note 3

Note 1. Unless specified, the ambient temperature $T_a = 25^{\circ}\text{C}$

Note 2. The recommended operating conditions refer to a range in which operation of this product is guaranteed. The operation cannot be guaranteed if the absolute maximum values exceed.

Note 3. If LED is driven by high current, high ambient temperature and humidity condition, the lifetime of LED will be reduced. Operating life means brightness goes down to 50% initial brightness. Typical operating lifetime is estimated data.

8. ELECTRO-OPTICAL CHARACTERISTICS

ITEM	SYMBOL	CONDITION	MIN	TYP	MAX	UNIT	RMK	NOTE
Response Time	Tr+Tf	$\theta=0^\circ$	-	30	-	ms	FIG 1.	4, 7
Contrast Ratio	Cr	$\theta=0^\circ$ Ta=25 °C	-	900	-	---	FIG 2.	1, 7
Surface Luminance	Lv		-	750	-	cd/m ²		2, 7
Viewing Angle Range	θ	$\theta = 90^\circ$	-	80	-	deg	FIG 3.	6
		$\theta = 270^\circ$	-	80	-	deg		
		$\theta = 0^\circ$	-	80	-	deg		
		$\theta = 180^\circ$	-	80	-	deg		
CIE (x, y) Chromaticity	Rx	$\theta=0^\circ$	0.576	0.611	0.646	-	FIG 2.	5, 7
	Ry	$\theta=0^\circ$ Ta=25 °C	0.311	0.346	0.381	-		
	Gx		0.307	0.342	0.377	-		
	Gy		0.544	0.579	0.614	-		
	Bx		0.104	0.139	0.174	-		
	By		0.099	0.134	0.169	-		
	Wx		0.270	0.305	0.340	-		
	Wy		0.310	0.345	0.380	-		

Note 1. Contrast Ratio (CR) is defined mathematically as below, for more information see Figure 2.

$$\text{Contrast Ratio} = \frac{\text{Average Surface Luminance with all white pixels (P1, P2, P3, P4, P5)}}{\text{Average Surface Luminance with all black pixels (P1, P2, P3, P4, P5)}}$$

Note 2. Surface luminance is the LCD surface from the surface with all pixels displaying white. For more information see Figure 2.

$$L_v = \text{Average Surface Luminance with all white pixels (P1, P2, P3, P4, P5)}$$

Note 3. The uniformity in surface luminance δ WHITE is determined by measuring luminance at each test position 1 through 5, and then dividing the minimum luminance of 5 points luminance by maximum luminance of 5 points luminance. For more information see Figure 2.

$$\delta \text{ WHITE} = \frac{\text{Minimum Surface Luminance with all white pixels (P1, P2, P3, P4, P5)}}{\text{Maximum Surface Luminance with all white pixels (P1, P2, P3, P4, P5)}}$$

Note 4. Response time is the time required for the display to transition from white to black (Rise Time, T_r) and from black to white (Decay Time, T_f). For additional information see Figure 1. The test equipment is BM-7A.

Note 5. CIE (x, y) chromaticity, the x, y value is determined by measuring luminance at each test position 1 through 5, and then make average value.

Note 6. For TFT module, viewing angle is the angle at which the contrast ratio is greater 10. The angles are determined for the horizontal or x axis and the vertical or y axis with respect to the z axis which is normal to LCD surface. For more information see Figure 3.

Note 7. Viewing angle is measured at the center point of the LCD by CONOSCOPE (ergo-80). For response time testing, the testing data is based on BM-7A. Instruments for Contrast Ratio, Surface Luminance, Luminance Uniformity, Chromaticity the test data is based on SR-3A.

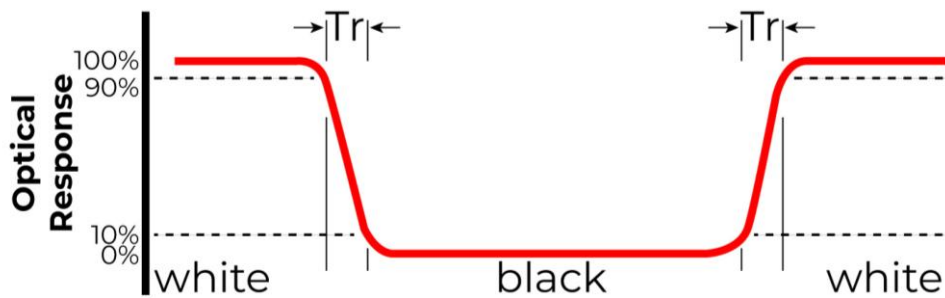

Figure 1. The definition of response time

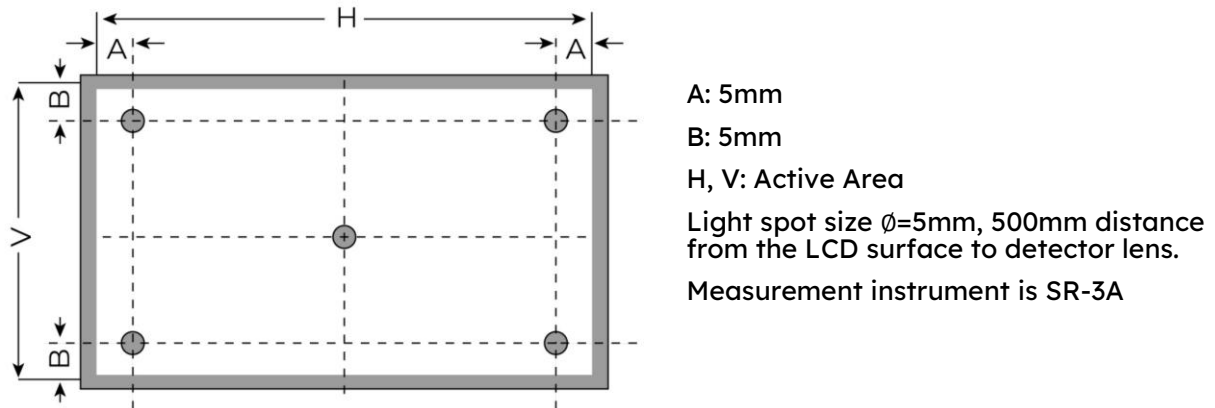

Figure 2. Measuring method for Contrast ratio, surface luminance, Luminance uniformity, CIE (x, y) chromaticity

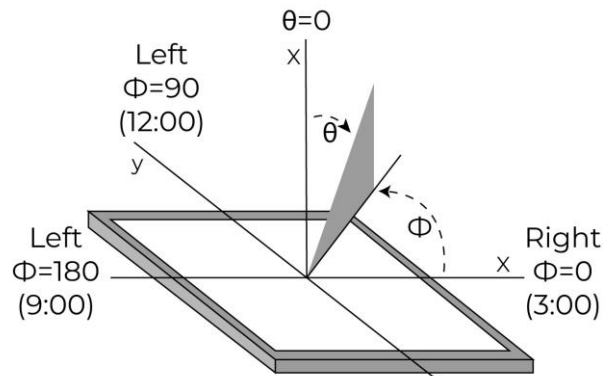
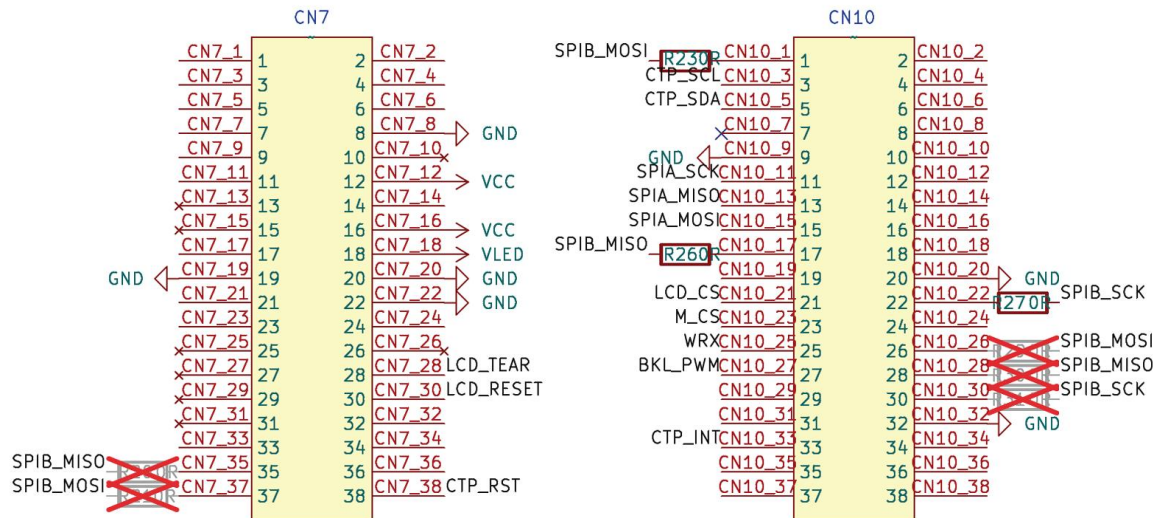

Figure 3. The definition of viewing angle

9. INTERFACES DESCRIPTION



9.1 CN7

PIN	SYMBOL	DESCRIPTION	I/O/P
8	GND	Ground	P
12	VCC	I/O reference power supply	P
16	VCC	Power supply 3.3V	P
18	VLED	Backlight power supply	P
19	GND	Ground	P
20	GND	Ground	P
22	GND	Ground	P
28	LCD_TEAR	Tear effect signal	O
30	LCD_RESET	LCD Reset	I
35	SPIB_MISO	SPI data output (Not connected)	O
37	SPIB_MOSI	SPI data input (Not connected)	I
38	CTP_RST	CTP Reset	I

9.2 CN10

PIN	SYMBOL	DESCRIPTION	I/O/P
1	SPIB_MOSI	SPI data input	I
3	CTP_SCL	CTP serial clock	I
5	CTP_SDA	CTP serial data	I/O
9	GND	Ground	P
11	SPIA_SCK	SPI serial clock	I
13	SPIA_MISO	SPI data output	O
15	SPIA_MOSI	SPI data input	I
17	SPIB_MISO	SPI data output	O
20	GND	Ground	P
21	LCD_CS	LCD chip select	I
22	SPIB_SCK	SPI serial clock	I
23	M_CS	Memory chip select	I
25	WRX	LCD command/data select	I
26	SPIB_MOSI	SPI data input (Not connected)	I
27	BKL_PWM	Backlight PWM control	I
28	SPIB_MISO	SPI data output (Not connected)	O
30	SPIB_SCK	SPI serial clock (Not connected)	I
32	GND	Ground	P
33	CTP_INT	CTP interrupt	I

10. EXTERNAL MEMORY

ITEM	DESCRIPTION
Flash	NOR Flash
Size	64Mbit/8Mbyte
Interface	SPI

11. CAPACITIVE TOUCH SCREEN PANEL SPECIFICATIONS

11.1 Mechanical characteristics

DESCRIPTION	SPECIFICATION
Touch Panel Size	1.54 inch
Outline Dimension of CTP	43.00mm x 36.00mm
Glass Thickness	1.1 mm
CTP View Area	28.34mm x 28.34mm
Sensor Active Area	27.72mm x 27.72mm
Surface Hardness	6H

11.2 Electrical characteristics

DESCRIPTION	SPECIFICATION
Controller	ILI2130
Resolution	240x240
Device address 7-bit	0x41

12. INSPECTION

Standard acceptance/rejection criteria for TFT module according to document available [here](#).

13. LEGAL INFORMATION

CE marking is usually obligatory only for a complete end product. Riverdi display modules are semi-finished goods which are used as inputs to become part of the finished products.

Therefore, Riverdi display modules are not CE marked.

This is not a standalone product. It was designed as an electronic component. It needs integration with a whole system to be fully functional.

Riverdi grants the guarantee for the proper operation of the goods for a period of 12 months from the date of possession of the goods. If in a consequence of this guaranteed execution the customer has received the defects-free item as replacement for the defective item, the effectiveness period of this guarantee shall start anew from the moment the customer receives the defects-free item.

Information about device is the property of Riverdi and may be the subject of patents pending or granted. It is not allowed to copy or disclosed this document without prior written permission.

Riverdi endeavors to ensure that all contained information in this document is correct but does not accept liability for any error or omission. Riverdi products are in developing process and published information may be not up to date. Riverdi reserves the right to update and makes changes to Specifications or written material without prior notice at any time. It is important to check the current position with Riverdi.

Images and graphics used in this document are only for illustrative the purpose. All images and graphics are possible to be displayed on the range products of Riverdi, however the quality may vary. Riverdi is no liable to the buyer or to any third party for any indirect, incidental, special, consequential, punitive, or exemplary damages (including without limitation lost profits, lost savings, or loss of business opportunity) relating to any product, service provided or to be provided by Riverdi, or the use or inability to use the same, even if Riverdi has been advised of the possibility of such damages.

Riverdi products are not fault tolerant nor designed, manufactured or intended for use or resale as on line control equipment in hazardous environments requiring fail-safe performance, such as in the operation of nuclear facilities, aircraft navigation or communication systems, air traffic control, direct life support machines or weapons systems in which the failure of the product could lead directly to death, personal injury or severe physical or environmental damage ('High-Risk Activities'). Riverdi and its suppliers specifically disclaim any expressed or implied warranty of fitness for High-Risk Activities. Using Riverdi products and devices in 'High-Risk Activities' and in any other application is entirely at the buyer's risk, and the buyer agrees to defend, indemnify and hold harmless Riverdi from all

damages, claims or expenses resulting from such use. No licenses are conveyed, implicitly or otherwise, under any Riverdi intellectual property rights.

14. CONTACT

Your Success is Our Priority

Stuck on a technical challenge? Need expert guidance?
Our dedicated support team is just a message away.

Contact us at
contact@riverdi.com

We're here to ensure your project's success, every step of the way!